

# FD135GH-2P

High efficiency multicrystal photovoltaic module



Frameless Kyocera solar module

## EXAMPLES OF APPLICATION

- Grid-connected systems, for e.g.
  - Residential solar power systems
  - Roof integrated installation
  - Façade installation
  - Special architectural solutions



Apartment house, France

## CUTTING-EDGE TECHNOLOGY

Exhaustive research work and continuous further development of production processes enable the integrated Kyocera high-performance solar cells with a standard size of 156 mm x 156 mm to achieve over 16 % efficiency, guaranteeing an extremely high annual yield of energy from the photovoltaic system.

To protect against the harshest weather conditions, the cells are embedded between a reinforced glass covering (hailstorm resistance complying with IEC 61215 ed. 2, tested by TÜV) and EVA foil, and are sealed with a PET foil backing.

The junction box on the module backside is equipped with bypass diodes that eliminate the risk of the individual solar cells overheating (hot spot effect). Many series-connected photovoltaic modules can be easily wired using pre-assembled solar cables and multi-contact plugs. With an appropriate installation system\*, the frameless solar module is especially suited for direct integration in the roof covering.

Kyocera manufactures all the components at its own production sites – without buying in semi-finished products – to ensure consistently high product quality.

TUVdotCOM Service: Internet platform for tested quality and service  
 TUVdotCom-ID: 0000023420  
 IEC 61215 ed. 2, IEC 61730 and Safety Class II  
 Kyocera is ISO 9001 and ISO 14001 certified and registered.



**KYOCERA  
SOLAR**

**We care!**

## SPECIFICATIONS

in mm

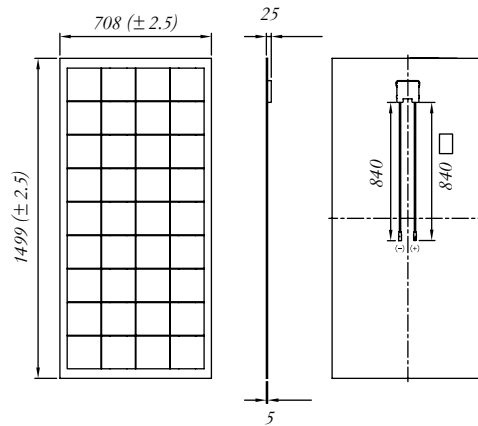

## ELECTRICAL CHARACTERISTICS

Current-Voltage characteristics at various cell temperatures

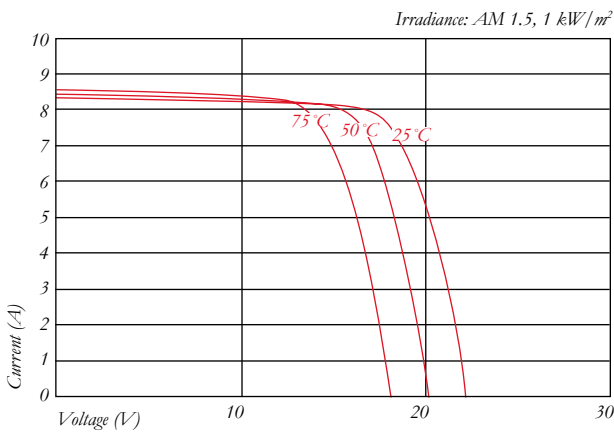

Current-Voltage characteristics at various irradiance levels

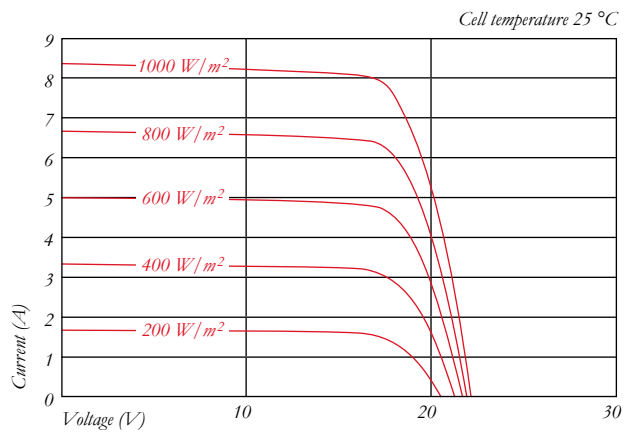

## ELECTRICAL PERFORMANCE

PV Module Type		FD135GH-2P
<b>At 1000 W/m<sup>2</sup> (STC)*</b>		
Maximum Power	[W]	135
Maximum System Voltage	[V]	1000
Maximum Power Voltage	[V]	17.7
Maximum Power Current	[A]	7.63
Open Circuit Voltage (V <sub>OC</sub> )	[V]	22.1
Short Circuit Current (I <sub>SC</sub> )	[A]	8.37
<b>At 800 W/m<sup>2</sup> (NOCT)**</b>		
Maximum Power	[W]	95
Maximum Power Voltage	[V]	15.7
Maximum Power Current	[A]	6.10
Open Circuit Voltage (V <sub>OC</sub> )	[V]	20.0
Short Circuit Current (I <sub>SC</sub> )	[A]	6.79
NOCT	[°C]	47.9
<b>Power Tolerance</b>		
Power Tolerance	[%]	+5 / -5
Maximum Reverse Current I <sub>R</sub>	[A]	15
Series Fuse Rating	[A]	15
Temperature Coefficient of V <sub>OC</sub>	[V/°C]	-0.80x10 <sup>-1</sup>
Temperature Coefficient of I <sub>SC</sub>	[A/°C]	5.02x10 <sup>-3</sup>
Temperature Coefficient of Max. Power	[W/°C]	-6.14x10 <sup>-1</sup>
Reduction of Efficiency (from 1000 W/m <sup>2</sup> to 200 W/m <sup>2</sup> )	[%]	5.8

## DIMENSIONS

Length	[mm]	1499 (±2.5)
Width	[mm]	708 (±2.5)
Depth / incl. Junction Box	[mm]	5 / 25
Weight	[kg]	10.9
Cable	[mm]	(+)840 / (-)840
Connection Type		MC PV-KBT3 / MC PV-KST3
Junction Box	[mm]	105x108x20
IP Code		IP65

## GENERAL INFORMATION

Performance Guarantee	10*** / 20 years****
Warranty	5 years*****

## CELLS

Number per Module	36
Cell Technology	polycrystalline
Cell Shape (square)	[mm] 156x156
Cell Bonding	3 busbar

\* Electrical values under standard test conditions (STC): irradiation of 1000 W/m<sup>2</sup>, airmass AM 1.5 and cell temperature of 25 °C

\*\* Electrical values under normal operating cell temperature (NOCT): irradiation of 800 W/m<sup>2</sup>, airmass AM 1.5, wind speed of 1 m/s and ambient temperature of 20 °C

\*\*\* 10 years on 90% of the minimally specified power P under standard test conditions (STC)

\*\*\*\* 20 years on 80% of the minimally specified power P under standard test conditions (STC)

for usage of a Solrif XL in-roof system

\*\*\*\*\* In the case of Europe

Your local Kyocera dealer:

**KYOCERA  
SOLAR**

**We care!**

**KYOCERA Fin ceramics GmbH  
Solar Division**  
Fritz-Mueller-Straße 27  
73730 Esslingen/Germany  
Tel: +49 (0)711-93 93 49 99  
Fax: +49 (0)711-93 93 49 50  
E-Mail: solar@kyocera.de  
www.kyocerasolar.de